

Other CruzPro Products

- Depthsounders, FishFinder & Speed/Temperature/Log
- DC Volts/Amps/Amp-Hour Monitor
- AC Volts/Amps/Freq/kW Monitor
- LPG/Petrol Gas Detectors/Alarms
- Bilge Water Alarms & Bilge Pump Controllers
- Windlass Controller/Chain Counter
- Digital Fuel Gauges & Fuel Consumption Calculator
- Digital Tankage Gauges/w Alarms
- Smart Alternator Regulators
- Marine Security System
- RPM/Engine Hours/Elapsed Time Gauge
- Digital Oil Pressure & Water Temp. Gauges/w Alarms
- Digital Rudder Angle Indicator
- One and Three Bank Digital Volts Gauges
- Digital Amps Gauge
- Digital Clock/Watch/Race Timers/Alarms
- 8 and 16 Amp Light Dimmers / Motor Speed Controller
- Solar Panel Charge Controllers 6/8/9 & 20 Amps
- 4 & 8 Channel NMEA Combiners/RS-232 Convertors
- Engine/Exhaust Temp. Monitor & Digital Pyrometer
- NMEA 0183 Remote Data Repeater/w 4 Input Channels

CruzPro®



EH55



Engine Hours Gauge

Page 1

Mounting and Wiring

- Drill a 2-1/8" (55mm) mounting hole where you desire to mount the instrument (Figure 1).
- Bring the power and ground lines out of the mounting hole and use a small flat screwdriver to make the connections to the screw terminal on the instrument case back as shown in figure 2.
- Carefully check all your wiring against those shown in figure 2. If everything is wired correctly, turn on the ignition switch and check the operation.

When mounting the EH55 in the instrument hole use only finger tension to tighten the bracket hold-down nuts *Do not overtighten the bracket or you may damage the case.*

Page 6

Introduction

The EH55 is a "no frills" low cost digital Engine Hours gauge which displays total engine hours from 000.0 hours to 9999 hours. A red LED backlight makes it easy to view the gauge at night. The EH55 is easy to install with only two wires connected to the ignition line and ground.

Page 3

Table of Contents

Introduction	3
Specifications	4
Installation	5
Other CruzPro Products	16

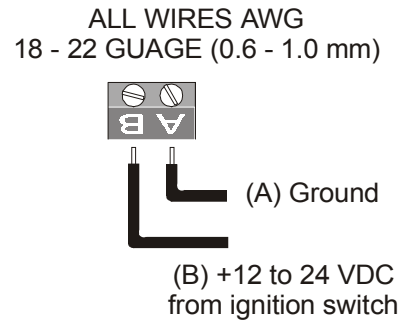

Figure 2 - Wiring Diagram

©2007 CruzPro Ltd. EH55MANA
<http://www.cruzpro.com> Made in New Zealand

Specifications

- Power supply:** 9.5 to 33.0 VDC, .035 amps nom.
- Operating temperature:** 32 to 122 F (0 to 50 C)
- Size:** 2.5" dia X 4.1" deep (61mm x 104 mm)
- Range:** 000.0 to 9999 hours.
- Display:** 4 digits
- Backlights:** Red LED for easy nighttime viewing

Installation

Before starting the installation, please read this entire section first. Be sure to install the bulkhead gasket before you install the instrument. Finger tighten the screws that mount the instrument bracket - do not use tools.

